

Folleto técnico

Válvulas de cierre SVA-S y SVA-L



Las válvulas de cierre SVA están disponibles en versiones con paso en ángulo y paso recto, así como con cuello estándar (SVA-S) y cuello largo (SVA-L).

Las válvulas de cierre han sido diseñadas para satisfacer todos los requisitos que presentan las aplicaciones de refrigeración industrial y proporcionar unas condiciones de flujo favorables, siendo fáciles de desmontar y reparar cuando es necesario.

El diseño del cono de la válvula garantiza un cierre perfecto y permite su uso en sistemas con pulsaciones y vibraciones intensas (unos fenómenos que, en particular, resultan habituales en las líneas de descarga).

Características

- Apto para HCFC, HFC, R-717 (amoníaco), R-744 (CO₂) y todos los refrigerantes inflamables.
- Concepto modular:
 - Cada carcasa de válvula está disponible con varios tipos de conexión y en tamaños diferentes.
 - Las válvulas SVA-S y SVA-L se pueden convertir en cualquier otro producto de la plataforma SVL Flexline™ (válvula de regulación de accionamiento manual, válvula de retención y cierre, válvula de retención o filtro) con sólo sustituir la pieza superior completa.
- La revisión de las válvulas resulta rápida y sencilla. Sustituir la pieza superior es fácil y no requiere soldaduras.
- Accesorios opcionales:
 - Volante industrial de gran resistencia, para aquellos casos en los que la válvula se deba accionar frecuentemente.
 - Caperuza, para aquellos casos en los que la válvula se deba accionar con poca frecuencia.
- Existen versiones con paso en ángulo y recto y con cuello estándar o largo (DN 15-40) que pueden instalarse en sistemas aislados.
- Cada tipo de válvula lleva claramente marcados su tipo, su tamaño y su rango de funcionamiento.
- Las válvulas y las caperuzas pueden bloquearse utilizando un cable de sellado, con el fin de evitar su accionamiento por parte de personal no autorizado.
- Asiento interno metálico:
 - DN 6-65 (1/4-2 1/2 in).
 - Asiento interno de teflón (PTFE):
 - DN 80-200 (3-8 in).
- Posibilitan el flujo en ambas direcciones.
- La carcasa y el casquillo están fabricados en acero para bajas temperaturas, de acuerdo con los requisitos de la Directiva de equipos a presión y de otros organismos de homologación internacionales.
- Incluyen pernos de acero inoxidable.
- Presión de trabajo máxima: 52 barg (754 psig).
- Rango de temperatura: De -60 a +150 °C (de -76 a +302 °F).
- Clasificación: DNV, CRN, BV, etc. Para obtener una lista actualizada con las homologaciones de los productos, póngase en contacto con su distribuidor local de Danfoss.

Diseño
Conexiones

Se encuentran disponibles con las siguientes conexiones:

- Boquilla para soldar de acero DIN (EN 10220)
- Boquilla para soldar de acero ANSI (B 36.10, calibre 80)
 - DN 6-40 (¼-1½ in)
- Boquilla para soldar de acero ANSI (B 36.10, calibre 40)
 - DN 50-200 (2-8 in)
- Boquilla para soldar de acero GOST (8734-75 + 8732-78),
 - DN 10 - 150 (¾ - 6 in.)
- Manguito para soldar de acero ANSI (B 16.11)
 - DN 15-50 (½-2 in)
- Rosca externa
 - G ½-G 7/8 in (ISO 228/1)
- Rosca interna hembra (FPT) NPT (ANSI/ASME B 1.20.1)
 - DN 15-32 (½-1¼ in)

Carcasa

Fabricada en acero especial resistente a bajas temperaturas.

Cono de la válvula

El cono de la válvula puede girar sobre el eje, lo que evita que se produzca fricción entre el cono y el asiento durante la apertura y el cierre de la válvula; además, su diseño especial impide que el cono gire a causa de las pulsaciones y las vibraciones cuando la válvula se encuentra abierta. Un anillo de apriete de teflón posibilita un sellado perfecto aplicando una fuerza de cierre mínima.

Eje

Fabricado en acero inoxidable pulido, resulta idóneo para realizar el sellado mediante un sello de reborde.

Prensaestopas

El prensaestopas, resistente a las bajas temperaturas, garantiza una hermeticidad perfecta dentro del rango de temperatura siguiente: de -60 a +150 °C (de -76 a +302 °F). Los prensaestopas incorporan un anillo rascador para evitar la entrada de suciedad y hielo en ellos.

Directiva de equipos a presión (DEP)

Las válvulas SVA están homologadas según los requisitos de la norma europea especificada en la Directiva de equipos a presión y poseen marcado CE.

Si desea obtener más información o conocer cuáles son las limitaciones de uso, consulte las instrucciones de instalación.

Instalación

Se recomienda instalar las válvulas respetando la dirección de flujo indicada por la flecha situada en el cuerpo de estas. Las válvulas pueden instalarse de forma que el flujo tenga lugar en la dirección opuesta, pero esto provocará una ligera reducción del valor k_v (y, por tanto, del valor de C_v).

Se trata de válvulas diseñadas para soportar una presión interna elevada. Sin embargo, el sistema de tuberías debería diseñarse en general de tal forma que se eviten las acumulaciones de líquido y se reduzca el riesgo asociado a la presión hidráulica generada por la expansión térmica.

Si desea obtener más información, consulte las instrucciones de instalación de las válvulas SVA.



Ejemplo de anillo de marcado



SVA			
Diámetro interior nominal	DN ≤ 25 mm (1 in)	DN 32-80 mm (1¼-3 in)	DN 100-200 mm (4-8 in)
Homologadas para	Fluidos pertenecientes al grupo I		
Categoría	Artículo 3, párrafo 3	II	III

Válvulas de cierre, SVA-S y SVA-L

Datos técnicos

- Refrigerantes
Apto para HCFC, HFC, R-717 (amoníaco), R-744 (CO₂) y todos los refrigerantes inflamables.
- Rango de temperatura
De -60 a +150 °C (de -76 a +302 °F).
- Presión de trabajo máxima
52 barg (754 psig).

Conexiones

DIN

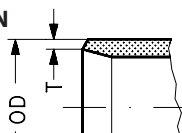

Tamaño mm	Tamaño in	OD mm	T mm	OD in	T in			k _v (en ángulo) m ³ /h	k _v (recto) m ³ /h	C _v (en ángulo) gal (US)/min	C _v (recto) gal (US)/min
-----------	-----------	-------	------	-------	------	--	--	--	--	---	-------------------------------------

Boquilla para soldar de acero DIN (EN 10220)

6	¼	13,5	2,3	0,531	0,091			2,9	2,0	3,4	2,4
10	⅜	17,2	2,3	0,677	0,091			4,5	3,2	5,2	3,6
15	½	21,3	2,3	0,839	0,091			7,0	4,9	8,1	5,7
20	¾	26,9	2,3	1,059	0,091			14,6	10,2	16,9	11,8
25	1	33,7	2,6	1,327	0,103			24,8	17,4	28,8	20,2
32	1¼	42,4	2,6	1,669	0,102			42,6	29,8	49,4	34,6
40	1½	48,3	2,6	1,902	0,103			45,2	31,6	52,4	36,7
50	2	60,3	2,9	2,37	0,11			80	65	93	76
65	2½	76,1	2,9	3	0,11			120	97	140	113
80	3	88,9	3,2	3,50	0,13			182	152	211	176
100	4	114,3	3,6	4,50	0,14			313	278	363	323
125	5	139,7	4,0	5,50	0,16			514	470	596	545
150	6	168,3	4,5	6,63	0,18			785	597	911	693
200	8	219,1	6,3	8,63	0,25			1168	1024	1355	1188

ANSI

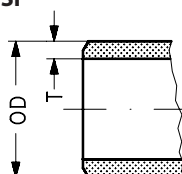

Tamaño mm	Tamaño in	OD mm	T mm	OD in	T in			k _v (en ángulo) m ³ /h	k _v (recto) m ³ /h	C _v (en ángulo) gal (US)/min	C _v (recto) gal (US)/min
-----------	-----------	-------	------	-------	------	--	--	--	--	---	-------------------------------------

Boquilla para soldar de acero ANSI (B 36.10, calibre 80)

6	¼	13,5	3,0	0,531	0,118			2,9	2,03	3,4	2,4
10	⅜	17,2	3,2	0,677	0,126			4,5	3,15	5,2	3,6
15	½	21,3	3,7	0,839	0,146			7,0	4,9	8,1	5,7
20	¾	26,9	4,0	1,059	0,158			14,6	10,2	16,9	11,8
25	1	33,7	4,6	1,327	0,181			24,8	17,4	28,8	20,2
32	1¼	42,4	4,9	1,669	0,193			42,6	29,8	49,4	34,6
40	1½	48,3	5,1	1,902	0,201			45,2	31,6	52,4	36,7

Boquilla para soldar de acero ANSI (B 36.10, calibre 40)

50	2	60,3	3,9	2,37	0,15			80	65	93	76
65	2½	73,0	5,2	2,87	0,20			120	97	140	113
80	3	88,9	5,5	3,50	0,22			182	152	211	176
100	4	114,3	6,0	4,50	0,24			313	278	363	323
125	5	141,3	6,6	5,56	0,26			514	470	596	545
150	6	168,3	7,1	6,63	0,28			785	597	911	693
200	8	219,1	8,2	8,63	0,32			1168	1024	1355	1188

GOST

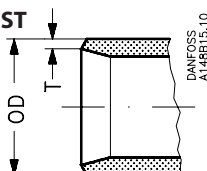

Tamaño mm	Tamaño in	OD mm	T mm	OD in	T in			k _v (en ángulo) m ³ /h	k _v (recto) m ³ /h	C _v (en ángulo) gal (US)/min	C _v (recto) gal (US)/min
-----------	-----------	-------	------	-------	------	--	--	--	--	---	-------------------------------------

Boquilla para soldar de acero GOST (8734-75 + 8732-78)

10	⅜	14	2	0,551	0,079			4,5	3,2	5,2	3,6
15	½	18	2	0,709	0,079			7	4,9	8,1	5,7
20	¾	25	2,5	0,984	0,098			14,6	10,2	16,9	11,8
25	1	32	3	1,260	0,118			24,8	17,4	28,8	20,2
32	1¼	38	3	1,496	0,118			42,6	29,8	49,4	34,6
40	1½	45	3	1,772	0,118			45,2	31,6	52,4	36,7
50	2	57	3,5	2,244	0,138			80	65	93	76
65	2½	76,1	2,9	3	0,11			120	97	140	113
80	3	88,9	3,2	3,50	0,13			182	152	211	176
100	4	108	4	4,252	0,157			313	278	363	323
125	5	133	4	5,236	0,157			514	470	596	545
150	6	159	4,5	6,260	0,177			785	597	911	693

Válvulas de cierre, SVA-S y SVA-L

Conexiones

Tamaño mm	Tamaño in	ID mm	T mm	ID in	T in	L mm	L in	k_v (en ángulo) m^3/h	k_v (recto) m^3/h	C_v (en ángulo) gal (US)/min	C_v (recto) gal (US)/min
-----------	-----------	-------	------	-------	------	------	------	---------------------------	-----------------------	--------------------------------	----------------------------

SOC

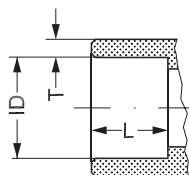

Manguito para soldar de acero ANSI (B 16.11)

15	1/2	21,8	6,0	0,858	0,235	10	0,39	7,0	4,9	8,1	5,7
20	3/4	27,2	4,6	1,071	0,181	13	0,51	14,6	10,9	16,9	11,8
25	1	33,9	7,2	1,335	0,284	13	0,51	24,8	17,4	28,8	20,2
32	1 1/4	42,7	6,1	1,743	0,240	13	0,51	42,6	29,8	49,4	34,6
40	1 1/2	48,8	6,6	1,921	0,260	13	0,51	45,2	31,6	52,4	36,7
50	2	61,2	6,2	2,41	0,24	16	0,63	80	65	93	76

Tamaño mm	Tamaño in	Rosca interna	k_v (en ángulo) m^3/h	k_v (recto) m^3/h	C_v (en ángulo) gal (US)/min	C_v (recto) gal (US)/min
-----------	-----------	---------------	---------------------------	-----------------------	--------------------------------	----------------------------

FPT

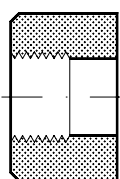

Rosca interna hembra (FPT) NPT (ANSI/ASME B 1.20.1)

15	1/2	(1/2 x 14 NPT)			8,5	6,0	9,9	7,0
20	3/4	(3/4 x 14 NPT)			10	7,0	11,6	8,1
25	1	(1 x 11,5 NPT)			32	22,4	37,1	26,0
32	1 1/4	(1 1/4 x 11,5 NPT)			36	25,2	41,8	29,3

Conexiones: SVA 6

T

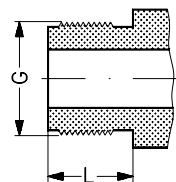

Tamaño		Rosca externa	L mm	L in	k_v (en ángulo) m^3/h	k_v (recto) m^3/h	C_v (en ángulo) gal (US)/min	C_v (recto) gal (US)/min
mm	in							

Rosca externa T (ISO 228/1)

6	1/4	G 1/2	16	0,63	2,5	2,0	2,9	2,0
---	-----	-------	----	------	-----	-----	-----	-----

ND

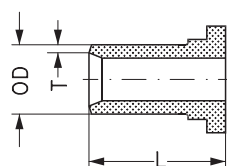

Manguitos para rosca externa T (ISO 228/1)

Tamaño mm	Tamaño in	OD mm	T mm	OD in	T in	L mm	L in	Rosca interna
-----------	-----------	-------	------	-------	------	------	------	---------------

Manguitos para soldar ND de acero (DIN 2448)

6	1/4	13,5	2,3	0,531	0,091	60	2,36	G1/2
---	-----	------	-----	-------	-------	----	------	------

NA

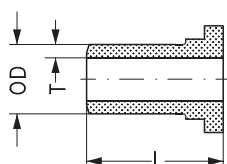

Tamaño mm	Tamaño in	OD mm	T mm	OD in	T in	L mm	L in	Rosca interna
-----------	-----------	-------	------	-------	------	------	------	---------------

Manguitos para soldar NA de acero ANSI (B 36.10, calibre 80)

6	1/4	13,5	3,0	0,531	0,118	60	2,36	G1/2
---	-----	------	-----	-------	-------	----	------	------

Especificaciones de materiales

SVA-S 6-10 (1/4"-3/8 in)

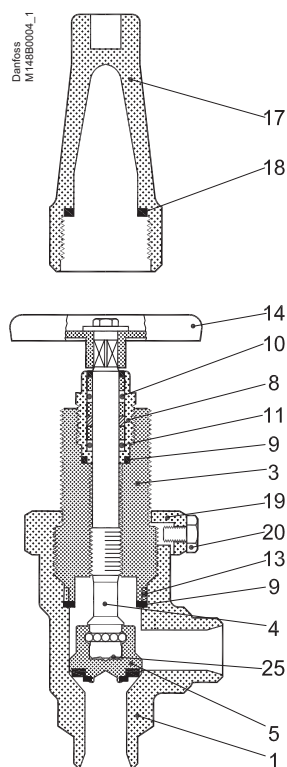

SVA-S 15-20 (1/2"-3/4 in)

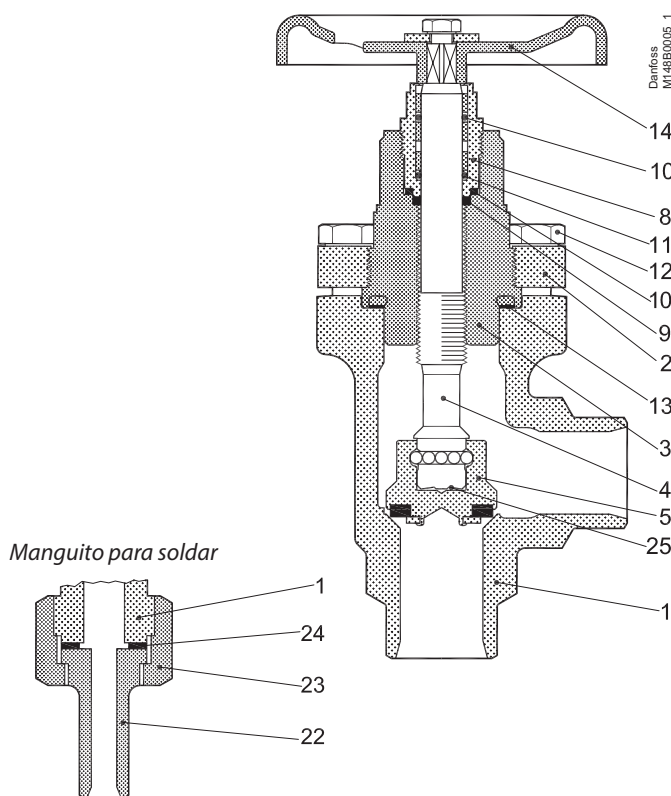

N.º	Componente	Material	EN	ISO	ASTM
1	Carcasa	Acero	G20Mn5QT, 10213-3 P285 QH+QT, 10222-4		LCC, A352 LF2, A350
2	Casquillo (brida)	Acero	G20Mn5QT, 10213-3 P285 QH+QT, 10222-4 P275NL, 10028-3		LCC, A352 LF2, A350
3	Casquillo (pieza)	Acero	11SMn30 10087	Tipo 2 R 683/9	AISI 1213
4	Eje	Acero inoxidable	X8CrNiS18-9 10088	Tipo 17 683/13	AISI 303
5	Cono	Acero	11SMn30 10087	Tipo 2 R 683/9	AISI 1213
8	Prensaestopas	Acero inoxidable	X8CrNiS18-9 10088	Tipo 17 683/13	AISI 303
9	Anillo de prensaestopas	Aluminio			
10	Junta tórica	Cloropreno (neopreno)			
11	Anillo de teflón accionado por muelle	Teflón (PTFE)			
12	Pernos	Acero inoxidable	A2-70	A2-70	Tipo 308
13	Junta	Fibra (sin amianto)			
14	Volante	Acero			
17	Caperuza	Aluminio			
18	Junta de la caperuza	Nailon			
19	Tuerca de sujeción	Acero			
20	Tornillo	Acero			
22	Manguito para soldar	Acero	S235JRG2 10025	Fe260B, 630	Grado C, A 283
23	Tuerca	Acero	11SMn30 10087	Tipo 2 R 683/9	AISI 1213
24	Anillo de prensaestopas	Sin amianto			
25	Muelle de disco	Acero			

Especificaciones de materiales

SVA-S 25-40 (1-1½ in)

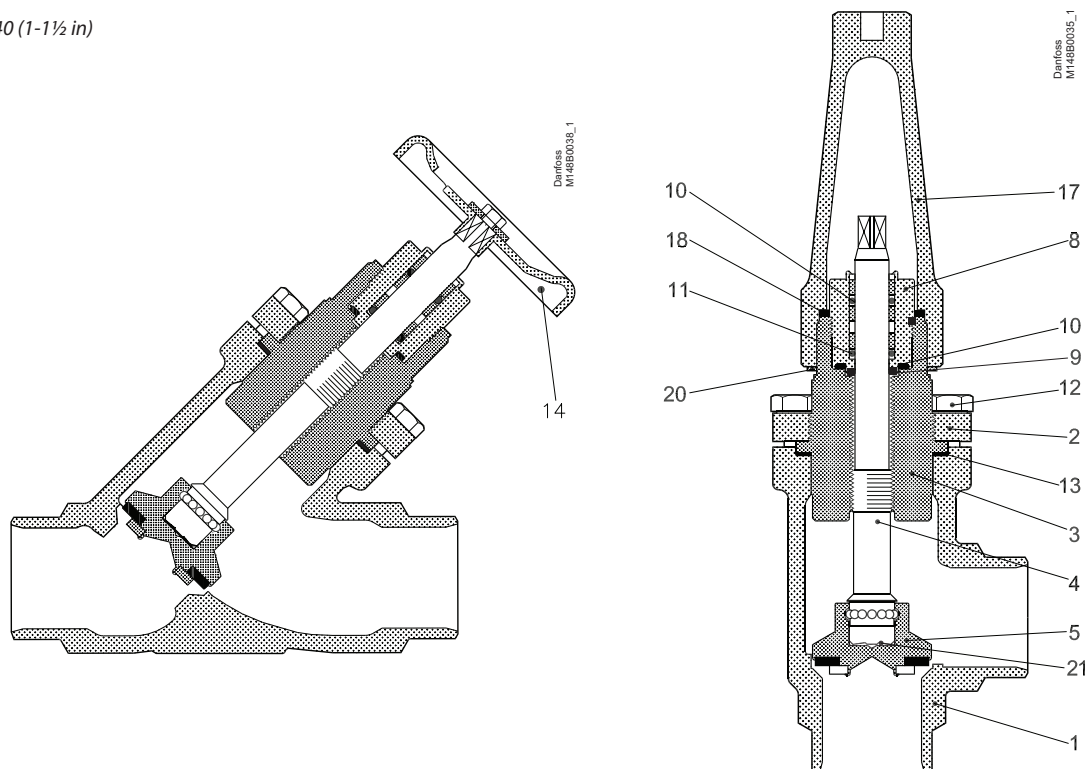

N.º	Componente	Material	EN	ISO	ASTM
1	Carcasa	Acero	G20Mn5QT, 10213-3 P285 QH+QT, 10222-4		LCC, A352 LF2, A350
2	Casquillo (brida)	Acero	G20Mn5QT, 10213-3 P285 QH+QT, 10222-4 P275NL, 10028-3		LCC, A352 LF2, A350
3	Casquillo (pieza)	Acero	11SMn30 10087	Tipo 2 R 683/9	AISI 1213
4	Eje	Acero inoxidable	X8CrNiS18-9 10088	Tipo 17 683/13	AISI 303
5	Cono	Acero	11SMn30 10087	Tipo 2 R 683/9	AISI 1213
8	Prensaestopas	Acero inoxidable	X8CrNiS18-9 10088	Tipo 17 683/13	AISI 303
9	Anillo de prensaestopas	Aluminio			
10	Junta tórica	Cloropreno (neopreno)			
11	Anillo de teflón accionado por muelle	Teflón (PTFE)			
12	Pernos	Acero inoxidable	A2-70	A2-70	Tipo 308
13	Junta	Fibra (sin amianto)			
14	Volante	Acero			
17	Caperuza	Aluminio			
18	Junta de la caperuza	Nailon			
20	Anillo de identificación	Acero inoxidable			
21	Muelle de disco	Acero			

Especificaciones de materiales

SVA-L 15-40 (1/2-1 1/2 in)

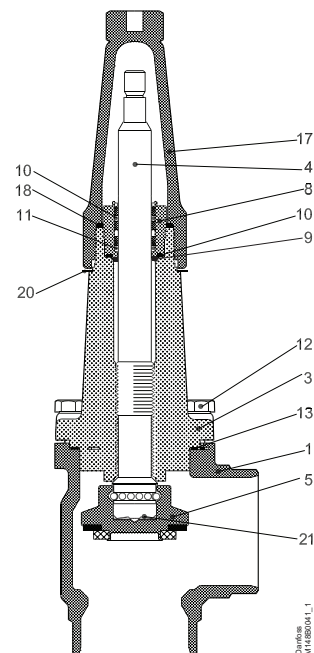
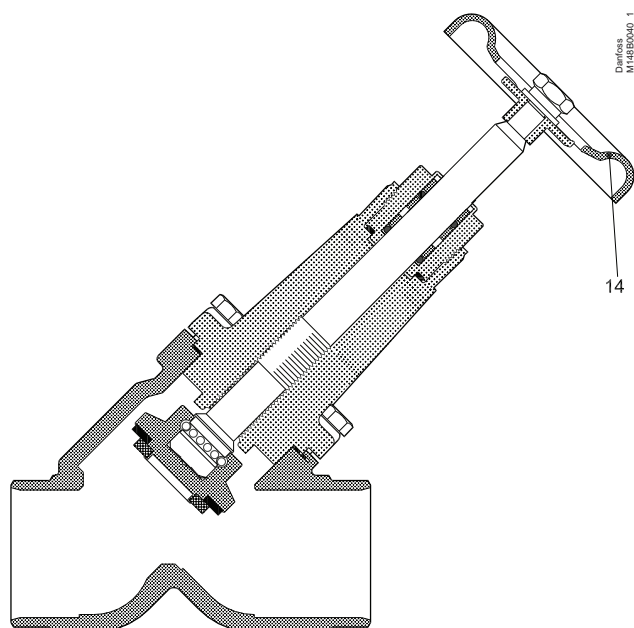

N.º	Componente	Material	EN	ISO	ASTM
1	Carcasa	Acero	G20Mn5QT, 10213-3 ----- P285 QH+QT, 10222-4		LCC, A352 ----- LF2, A350
3	Casquillo de la válvula	Acero	G20Mn5QT, 10213-3 ----- P285 QH+QT, 10222-4		LCC, A352 ----- LF2, A350
4	Eje	Acero inoxidable	X8CrNiS18-9 10088	Tipo 17 683/13	AISI 303
5	Cono	Acero	11SMn30 10087	Tipo 2 R 683/9	AISI 1213
8	Prensaestopas	Acero inoxidable	X8CrNiS18-9 10088	Tipo 17 683/13	AISI 303
9	Anillo de prensaestopas	Aluminio			
10	Junta tórica	Cloropreno (neopreno)			
11	Anillo de teflón accionado por muelle	Teflón (PTFE)			
12	Pernos	Acero inoxidable	A2-70	A2-70	Tipo 308
13	Junta	Fibra (sin amianto)			
14	Volante	Acero			
17	Caperuza	Aluminio			
18	Junta de la caperuza	Nailon (PA 6)			
20	Anillo de identificación	Acero inoxidable			
21	Muelle de disco	Acero			

Especificaciones de materiales

SVA-S 50-65 (2-2½ in)

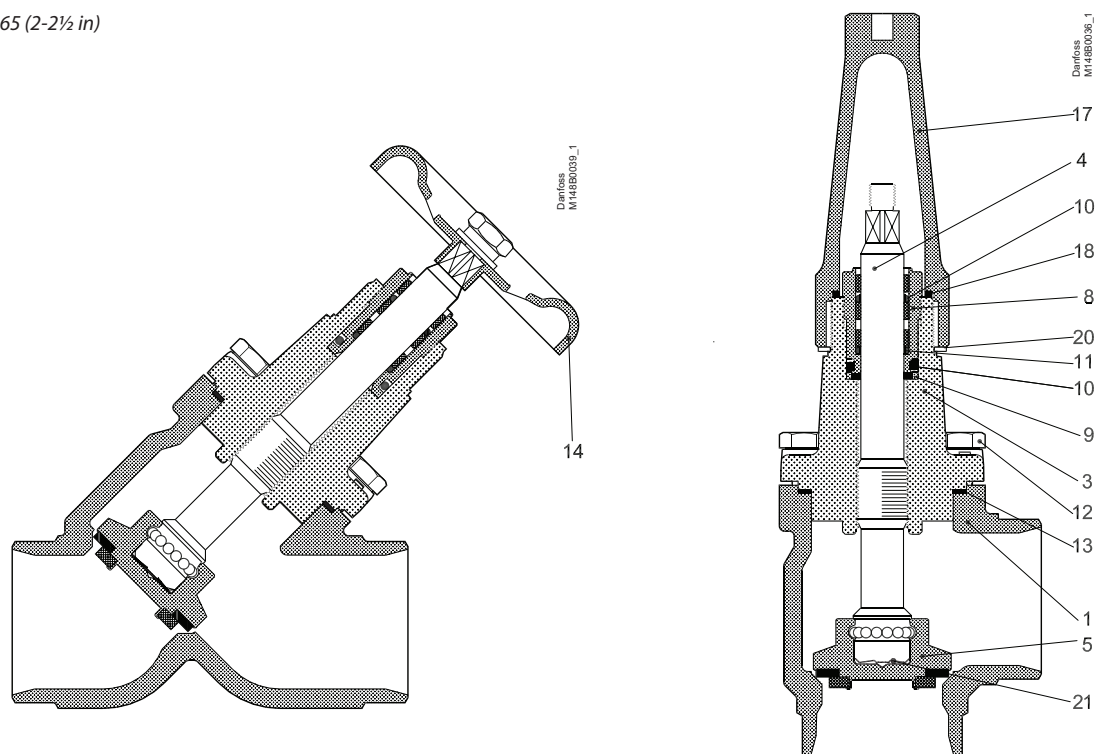

N.º	Componente	Material	EN	ISO	ASTM
1	Carcasa	Acero	G20Mn5QT, 10213-3 P285 QH+QT, 10222-4		LCC, A352 LF2, A350
3	Casquillo de la válvula	Acero	G20Mn5QT, 10213-3 P285 QH+QT, 10222-4		LCC, A352 LF2, A350
4	Eje	Acero inoxidable	X8CrNiS18-9 10088 DIN 17440 (sólo SVA-SS)	Tipo 17 683/13	AISI 303
5	Cono	Acero	115Mn30 10087	Tipo 2 R 683/9	AISI 1213
8	Prensaestopas	Acero inoxidable	X8CrNiS18-9 10088	Tipo 17 683/13	AISI 303
9	Anillo de prensaestopas	Aluminio			
10	Junta tórica	Cloropreno (neopreno)			
11	Anillo de teflón accionado por muelle	Teflón (PTFE)			
12	Pernos	Acero inoxidable	A2-70	A2-70	Tipo 308
13	Junta	Fibra (sin amianto)			
14	Volante	Acero			
17	Caperuza	Aluminio			
18	Junta de la caperuza	Nailon			
19	Tuerca de sujeción	Acero			
20	Anillo de identificación	Acero inoxidable			
21	Muelle de disco	Acero			

Especificaciones de materiales

SVA-S 80-150 (3-6 in)

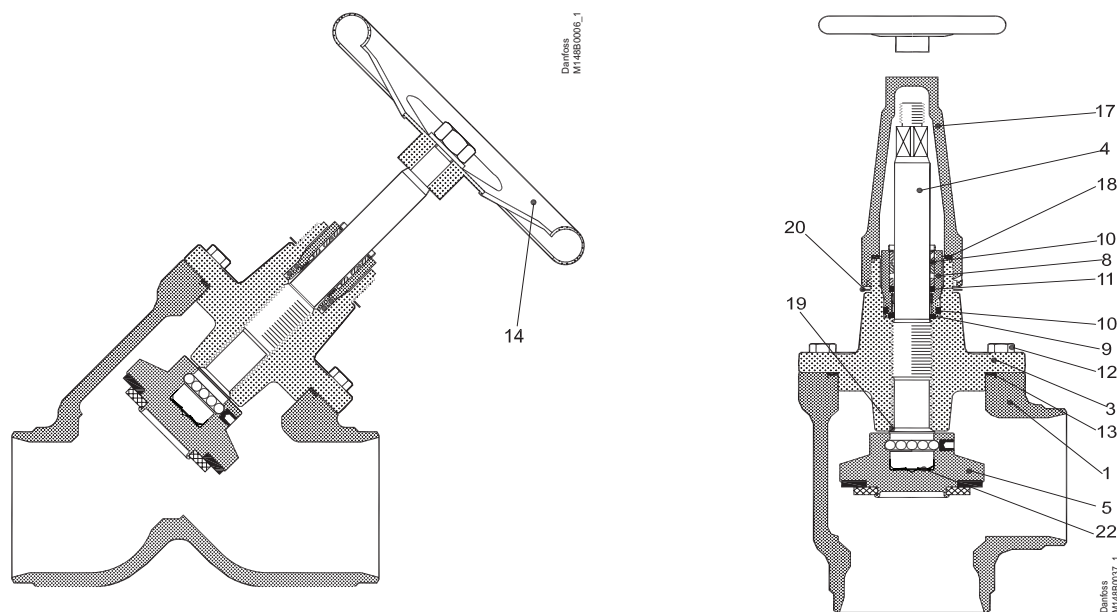

N.º	Componente	Material	EN	ISO	ASTM
1	Carcasa	Acero	G20Mn5QT 10213-3		LCC A352
3	Casquillo de la válvula	Acero	G20Mn5QT, 10213-3 P285 QH+QT, 10222-4		LCC, A352 LF2, A350
4	Eje	Acero inoxidable	X5CrNi18-10 10088	Tipo 11 R 683/13	AISI 304 A276
5	Cono Sello del cono	Acero Teflón (PTFE)	115Mn30 10087	Tipo 2, R 683/9	AISI 1213
8	Prensaestopas	Acero inoxidable	X8CrNiS18-9 10088	Tipo 17 R 683/13	AISI 303
9	Anillo de prensaestopas	Aluminio			
10	Junta tórica	Cloropreno (neopreno)			
11	Anillo de teflón accionado por muelle	Teflón (PTFE)			
12	Pernos	Acero inoxidable	A2-70	A2-70	Tipo 308
13	Junta	Fibra (sin amianto)			
14	Volante	Acero			
17	Caperuza	Aluminio			
18	Junta de la caperuza	Nailon (PA 6)			
19	Asiento posterior flexible	Teflón (PTFE)			
20	Anillo de identificación	Acero inoxidable			
22	Muelle de disco	Acero			

Especificaciones de materiales

SVA-S 200 (8 in)

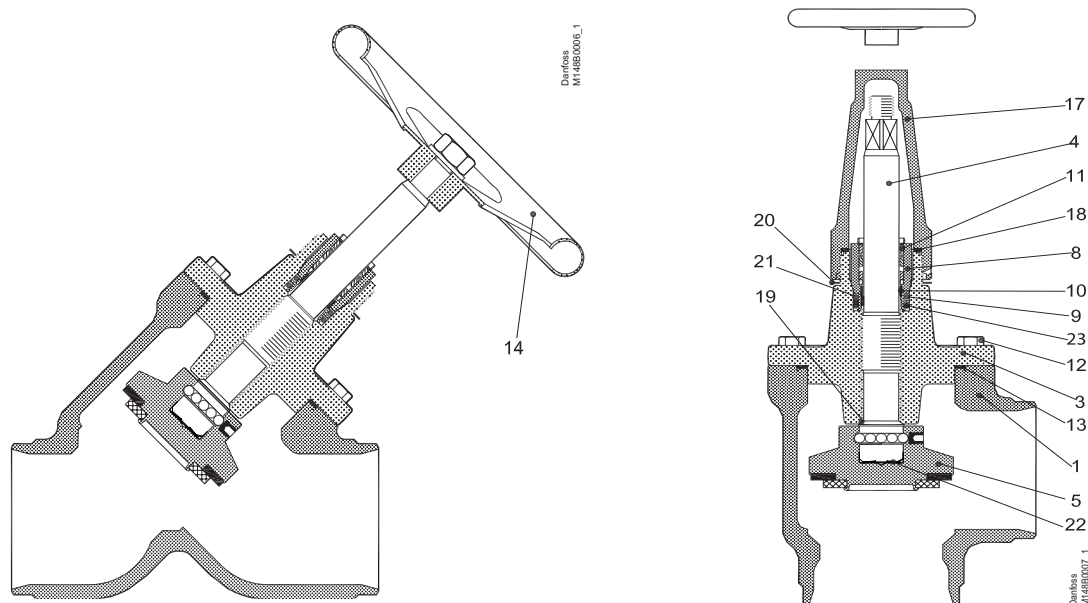

N.º	Componente	Material	EN	ISO	ASTM
1	Carcasa	Acero	G20Mn5QT 10213-3		LCC A352
3	Casquillo de la válvula	Acero	G20Mn5QT, 10213-3 ----- P285 QH+QT, 10222-4		LCC, A352 ----- LF2, A350
4	Eje	Acero inoxidable	X5CrNi18-10 10088	Tipo 11 R 683/13	AISI 304 A276
5	Cono Sello del cono	Acero Teflón (PTFE)	11SMn30 10087	Tipo 2, R 683/9	AISI 1213
8	Prensaestopas	Acero inoxidable	X8CrNiS18-9 10088	Tipo 17 R 683/13	AISI 303
9	Junta tórica	Cloropreno (neopreno)			
10	Anillo de teflón accionado por muelle	Teflón (PTFE)			
11	Junta tórica	Cloropreno (neopreno)			
12	Pernos	Acero inoxidable	A2-70	A2-70	Tipo 308
13	Junta	Fibra (sin amianto)			
14	Volante	Acero			
15	Arandela	Acero inoxidable			
16	Tuerca	Acero inoxidable			
17	Caperuza	Aluminio			
18	Junta de la caperuza	Nailon (PA 6)			
19	Asiento posterior flexible	Teflón (PTFE)			
20	Anillo de identificación	Acero inoxidable			
21	Anillo de desgaste	Teflón (PTFE)			
22	Muelle de disco	Acero			
23	Junta tórica	Teflón (PTFE)/cloropreno (neopreno)			

Válvulas de cierre, SVA-S y SVA-L

Dimensiones y pesos

SVA 6-10 con paso en ángulo y volante

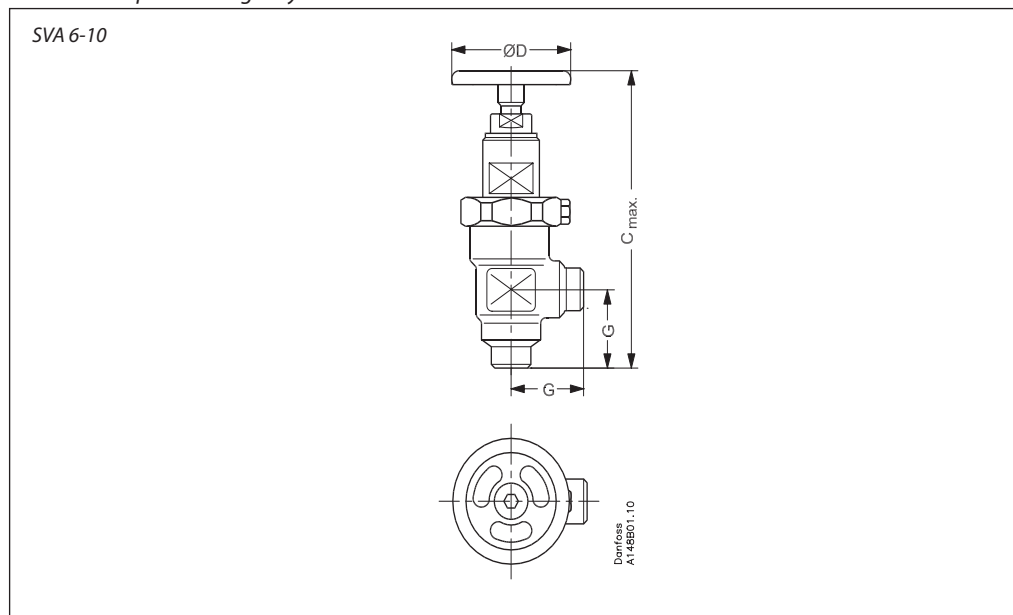

Tamaño de la válvula		C _{máx.}	G	ØD	□H	Peso
----------------------	--	-------------------	---	----	----	------

SVA 6	mm in	128 5,04	30 1,18	50 1,97		0,7 kg
SVA 10	mm in	173 6,81	45 1,77	60 2,36	60 2,36	1,4 kg

SVA 6-10 con paso en ángulo y caperuza

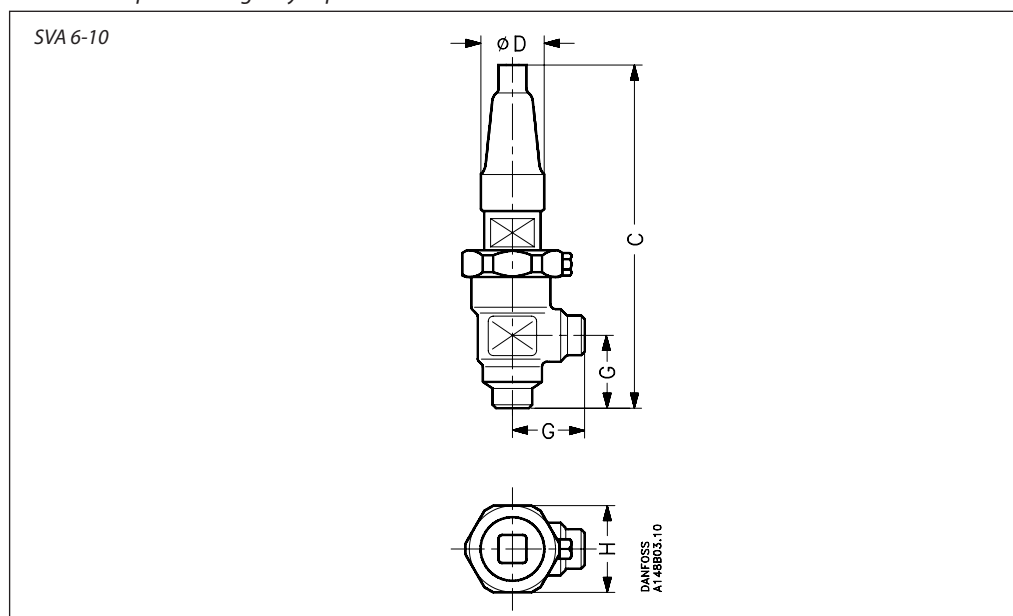

Tamaño de la válvula		C	G	ØD	□H	Peso
----------------------	--	---	---	----	----	------

SVA 6	mm in	139 5,47	30 1,18	30 1,18	48 1,89	0,8 kg
SVA 10	mm in	182 7,17	45 1,77	38 1,50	60 2,36	1,4 kg

Los pesos especificados únicamente son valores aproximados.

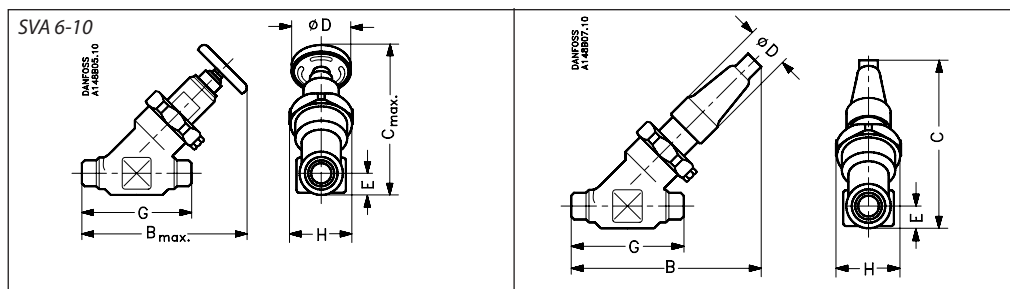
Dimensiones y pesos

SVA 6-10 con paso recto y volante

Tamaño de la válvula		C _{máx.}	B _{máx.}	E	G	ØD	□H	Peso
SVA 6	mm in.	11, 4,33	120 4,72	13 0,49	70 2,76	50 1,97	48 1,89	0,7 kg
SVA 10	mm in.	145 5,71	160 6,30	20 0,79	120 4,72	60 2,36	60 2,36	2,0 kg

SVA 6-10 con paso recto y caperuza

Tamaño de la válvula		C	B	E	G	ØD	□H	Peso
SVA 6	mm in.	110 4,33	120 4,72	13 0,49	70 2,76	30 1,16	48 1,89	0,8 kg
SVA 10	mm in.	145 5,71	155 6,10	20 0,79	120 4,72	38 1,50	60 2,36	2,0 kg

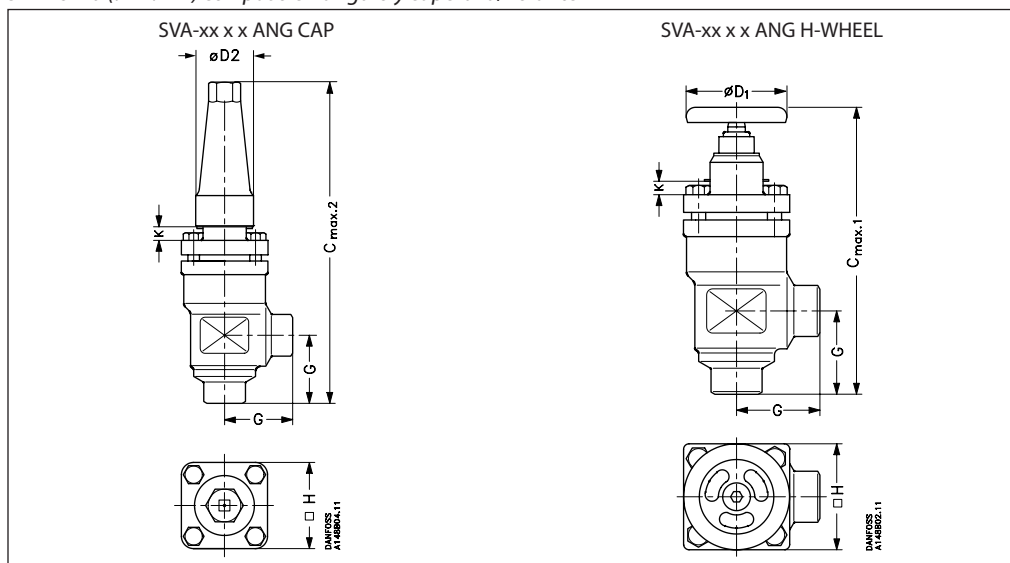
Los pesos especificados únicamente son valores aproximados.

SVA 15-40 (½-1½ in) con paso en ángulo y caperuza/volante

Tamaño de la válvula	K	C _{máx.1}	C _{máx.2}	G	ØD ₁	ØD ₂	□H	Peso
----------------------	---	--------------------	--------------------	---	-----------------	-----------------	----	------

SVA-S

SVA 15-20	mm	4	178	189	45	60	38	60	1,4 kg
SVA (½-¾)	in	0,16	7,00	7,44	1,77	2,36	1,5	2,36	3,1 lb
SVA 25-40	mm	12	234	268	55	80	50	70	2,4 kg
SVA (1-1½)	in	0,47	9,21	10,55	2,17	3,15	1,97	2,76	5,3 lb

SVA-S con manguito para soldar de acero

SVA 32-40	mm	12	241	275	62	80	50	70	2,9 kg
SVA (1¼-1½)	in	0,47	9,49	10,83	2,44	3,15	1,97	2,76	6,4 lb

SVA-L

SVA 15-20	mm	63	237	248	45	60	38	60	1,4 kg
SVA (½-¾)	in	2,48	9,33	9,76	1,77	2,36	1,5	2,36	3,1 lb
SVA 25-40	mm	74	296	330	55	80	50	70	2,4 kg
SVA (1-1½)	in	2,91	11,65	12,99	2,17	3,15	1,97	2,76	5,3 lb

SVA-L con manguito para soldar de acero

SVA 32-40	mm	74	303	337	62	80	50	70	2,9 kg
SVA (1¼-1½)	in	2,91	11,93	13,27	2,44	3,15	1,97	2,76	6,4 lb

Los pesos especificados únicamente son valores aproximados.

Válvulas de cierre, SVA-S y SVA-L

Dimensiones y pesos

SVA 15-40 (½-1½ in) con paso recto y caperuza/volante

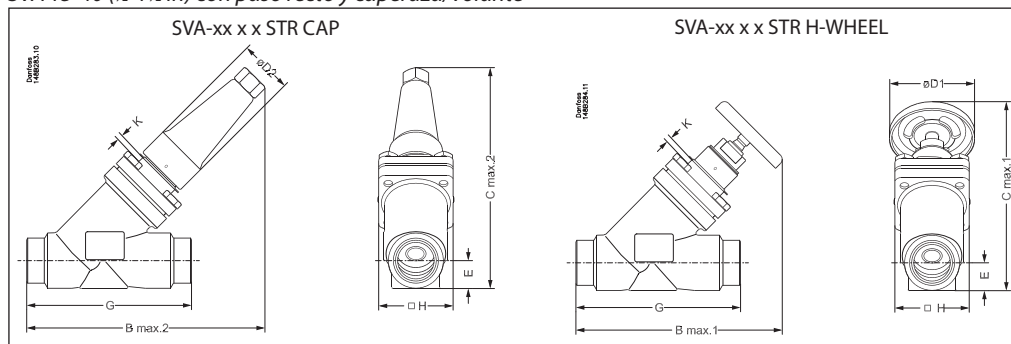

Tamaño de la válvula	K	C _{máx.1}	C _{máx.2}	B _{máx.1}	B _{máx.2}	E	G	ØD ₁	ØD ₂	□H	Peso
----------------------	---	--------------------	--------------------	--------------------	--------------------	---	---	-----------------	-----------------	----	------

SVA-S

SVA 15-20	mm	4	146	141	160	156	20	120	60	38	60	2,0 kg
SVA (½-¾)	in	0,16	5,74	5,55	6,30	6,14	0,79	4,72	2,36	1,50	2,36	4,4 lb
SVA 25-40	mm	12	199	208	212	222	26	155	80	50	70	3,0 kg
SVA (1-1½)	in	0,47	7,83	8,19	8,35	8,74	1,02	6,10	3,15	1,97	2,76	6,6 lb

SVA-S con manguito para soldar de acero

SVA 32	mm	12	200	209	212	222	27,4	155	80	50	70	3,0 kg
SVA (1¼)	in	0,47	7,87	8,23	8,35	8,74	1,08	6,10	3,15	1,97	2,76	6,6 lb
SVA 40	mm	12	204	213	212	222	31,0	155	80	50	70	3,0 kg
SVA (1½)	in	0,47	8,03	8,39	8,35	8,74	1,22	6,10	3,15	1,97	2,76	6,6 lb

SVA-L

SVA 15-20	mm	63	188	184	202	198	20	120	60	38	60	2,0 kg
SVA (½-¾)	in	2,48	7,40	7,24	7,95	7,80	0,79	4,72	2,36	1,50	2,36	4,4 lb
SVA 25-40	mm	74	243	252	256	265	26	155	80	50	70	3,0 kg
SVA (1-1½)	in	2,91	9,57	9,92	10,08	10,43	1,02	6,10	3,15	1,97	2,76	6,6 lb

SVA-L con manguito para soldar de acero

SVA 32	mm	74	244	253	256	265	27,4	155	80	50	70	3,0 kg
SVA (1¼)	in	2,91	9,61	9,96	10,08	10,43	1,08	6,10	3,15	1,97	2,76	6,6 lb
SVA 40	mm	74	248	257	256	265	31,0	155	80	50	70	3,0 kg
SVA (1½)	in	2,91	9,76	10,12	10,08	10,43	1,22	6,10	3,15	1,97	2,76	6,6 lb

Los pesos especificados únicamente son valores aproximados.

Dimensiones y pesos

SVA 50-65 (2-2½ in) con paso en ángulo y caperuza/volante

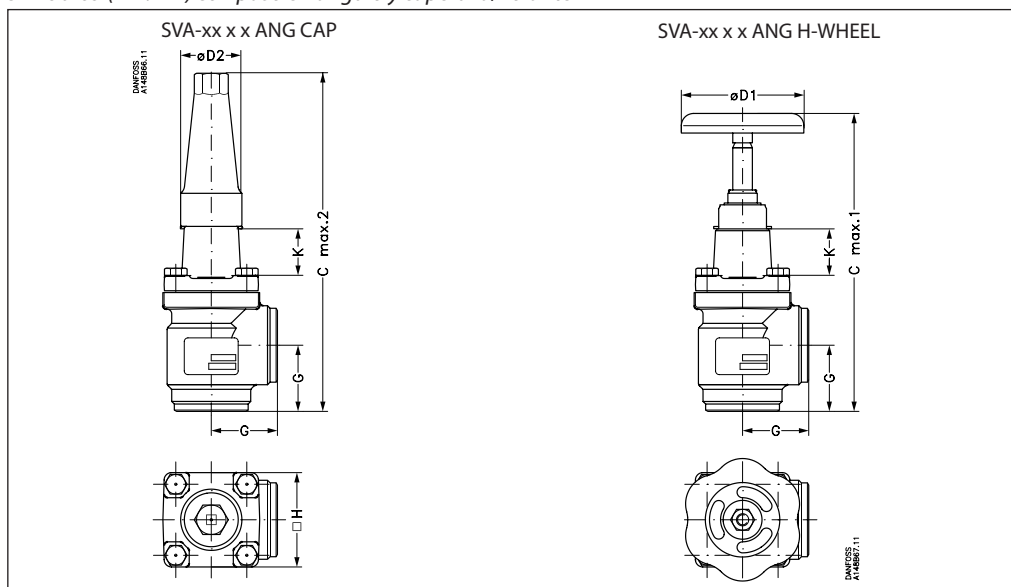

Tamaño de la válvula	K	C _{máx.1}	C _{máx.2}	G	ØD ₁	ØD ₂	□H	Peso
----------------------	---	--------------------	--------------------	---	-----------------	-----------------	----	------

SVA-S

SVA 50	mm	70	284	315	60	100	50	77	3,2 kg
SVA (2)	in	2,76	11,18	12,40	2,36	3,94	1,97	3,03	7,1 lb
SVA 65	mm	70	310	335	70	100	50	90	4,8 kg
SVA (2½)	in	2,76	12,20	13,19	2,76	3,94	1,97	3,54	10,6 lb

SVA-S con manguito para soldar de acero

SVA 50	mm	70	289	320	65	100	50	77	4,1 kg
SVA (2)	in	2,76	11,38	12,60	2,56	3,94	1,97	3,03	9,0 lb

Los pesos especificados únicamente son valores aproximados.

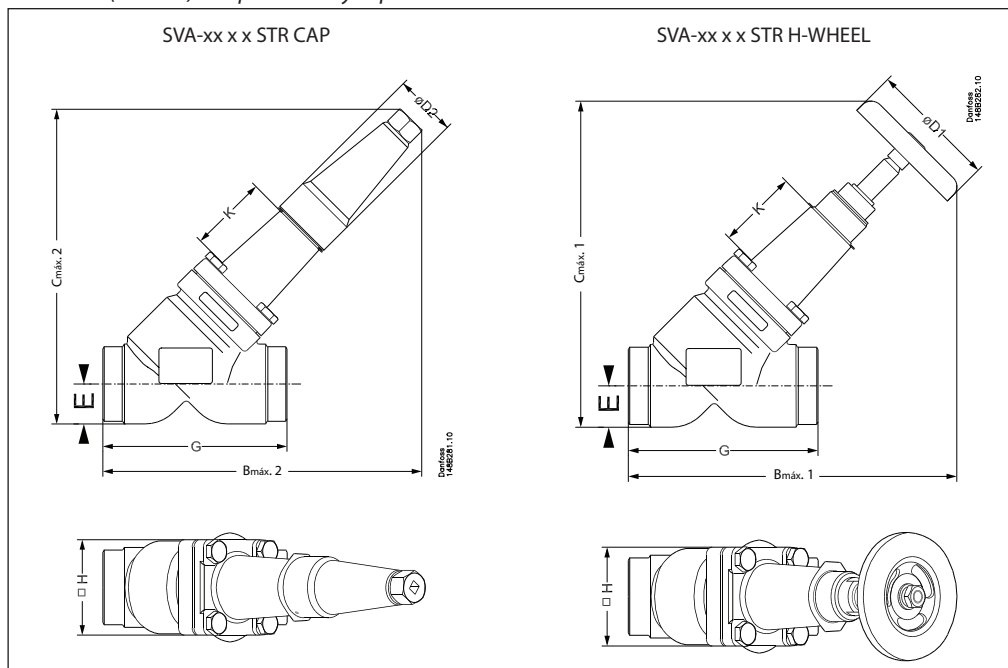
Dimensiones y pesos
SVA 50-65 (2-2½ in) con paso recto y caperuza/volante

Tamaño de la válvula	K	B _{máx.1}	B _{máx.2}	C _{máx.1}	C _{máx.2}	E	G	ØD ₁	ØD ₂	H	Peso
----------------------	---	--------------------	--------------------	--------------------	--------------------	---	---	-----------------	-----------------	---	------

SVA-S

SVA 50	mm	70	259	259	257	257	32	148	100	50	77	4,2 kg
SVA (2)	in	2,76	10,20	10,20	10,12	10,12	1,26	5,83	3,94	1,97	3,03	9,3 lb
SVA 65	mm	70	284	280	284	280	40	176	100	50	90	6,3 kg
SVA (2½)	in	2,76	11,18	11,02	11,18	11,02	1,57	6,93	3,94	1,97	3,54	13,9 lb

SVA-S con manquito para soldar de acero

SVA 50	mm	70	266	266	261	261	37	162	100	50	77	5,1 kg
SVA (2)	in	2,76	10,47	10,47	10,28	10,28	1,26	6,38	3,94	1,97	3,03	11,2 lb

Los pesos especificados únicamente son valores aproximados.

Válvulas de cierre, SVA-S y SVA-L

Dimensiones y pesos

SVA 80-200 (3-8 in) con paso en ángulo y caperuza/volante

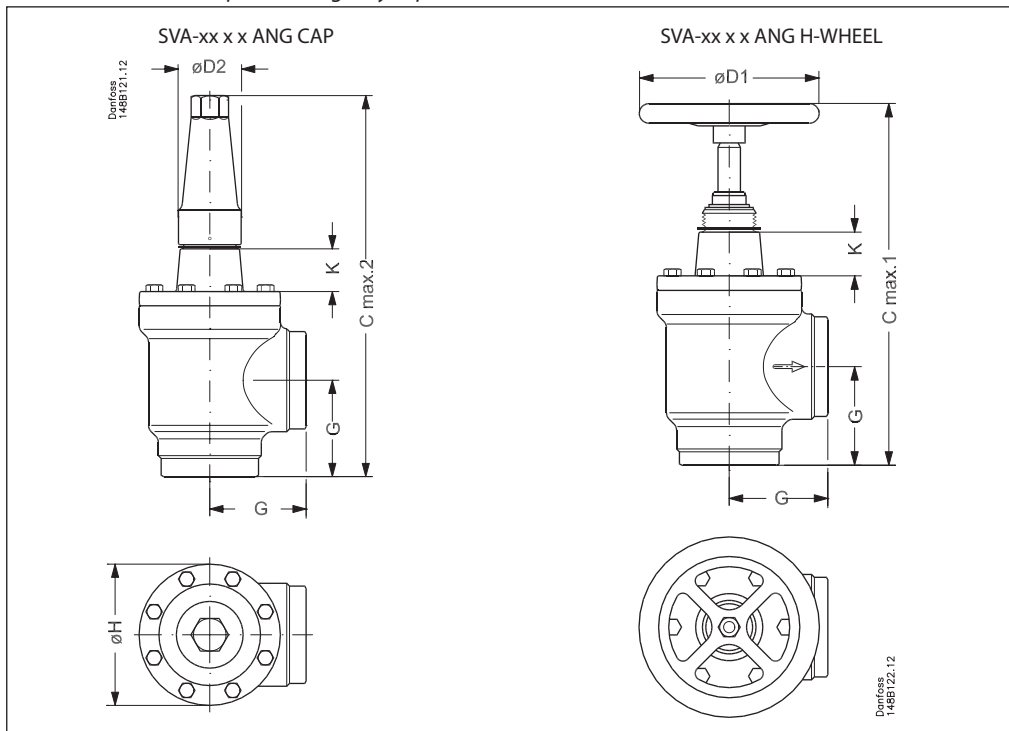

Tamaño de la válvula	K	C _{máx.1}	C _{máx.2}	G	ØD ₁	ØD ₂	ØH	Peso
SVA-S								
SVA 80	mm	76	373	90	200	58	129	9,7 kg
SVA (3)	in.	3,00	14,69	3,54	7,87	2,28	5,08	21,4 lb
SVA 100	mm	90	432	106	250	58	156	15,3 kg
SVA (4)	in.	3,54	17,00	4,17	9,84	2,28	6,14	33,7 lb
SVA 125	mm	90	517	128	315	74	193	28,1 kg
SVA (5)	in.	3,54	20,35	5,04	12,40	2,91	7,60	61,9 lb
SVA 150	mm	90	564	145	315	74	219	39,7 kg
SVA (6)	in.	3,54	22,20	5,71	12,40	2,91	8,62	87,5 lb
SVA 200	mm	90	677	180	400	86	276	79,5 kg
SVA (8)	in.	3,54	26,63	7,09	15,75	3,39	10,87	175,3 lb

Los pesos especificados únicamente son valores aproximados.

Válvulas de cierre, SVA-S y SVA-L

Dimensiones y pesos SVA 80-200 (3-8 in) con paso recto y caperuza/volante

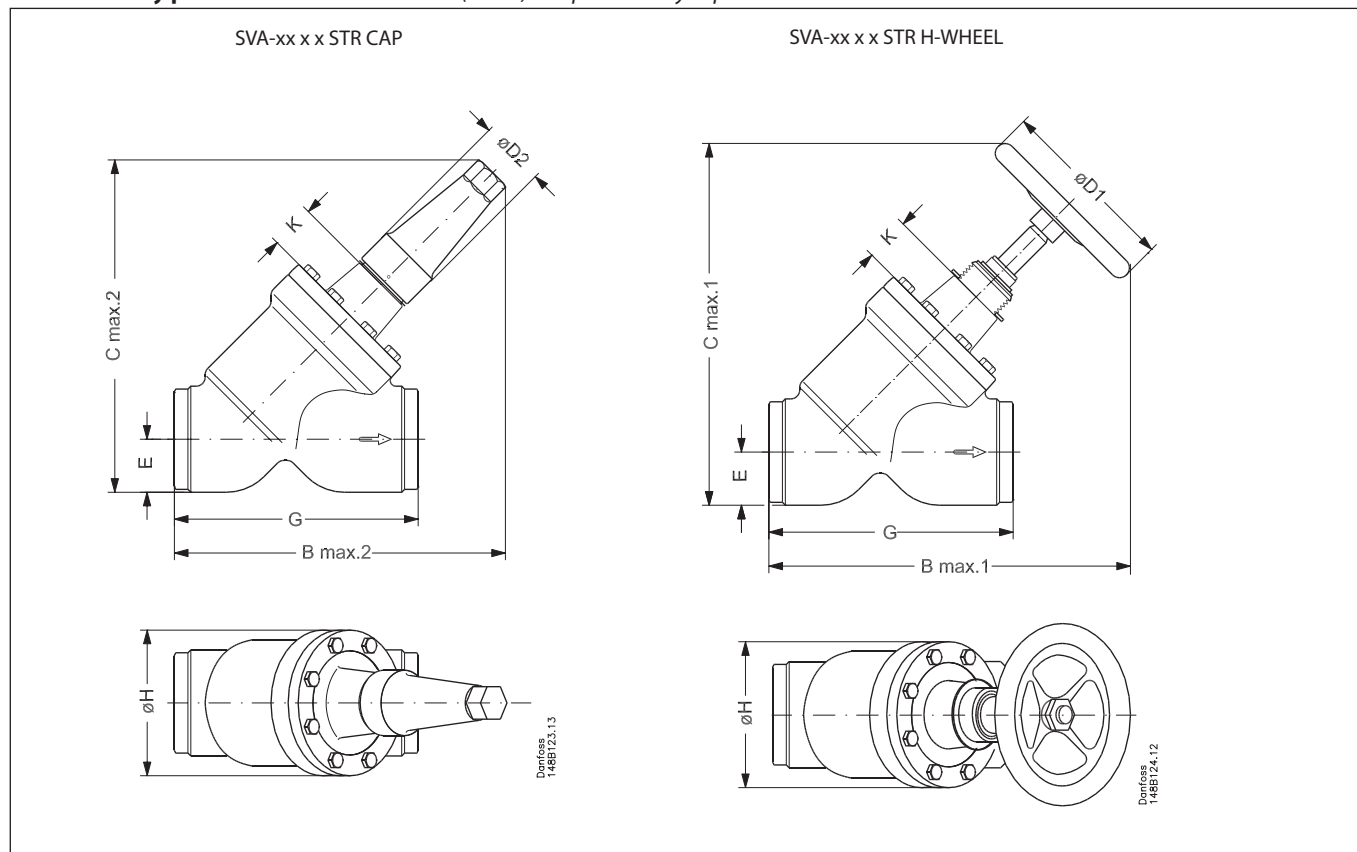

Tamaño de la válvula	K	B _{máx.1}	B _{máx.2}	C _{máx.1}	C _{máx.2}	E	G	$\varnothing D_1$	$\varnothing D_2$	$\varnothing H$	Peso	
SVA-S												
SVA 80	mm	76	365	321	367	322	48	216	200	58	129	10,9 kg
SVA (3)	in.	3,00	14,37	12,64	14,45	12,72	1,89	8,50	7,87	2,28	5,08	24,0 lb
SVA 100	mm	90	435	367	443	375	60	264	250	58	156	18,2 kg
SVA (4)	in.	3,54	17,13	14,45	17,44	14,76	2,36	10,39	9,84	2,28	6,14	40,1 lb
SVA 125	mm	90	526	444	538	456	74	322	315	74	193	32,8 kg
SVA (5)	in.	3,54	20,71	17,48	21,18	17,95	2,91	12,68	12,40	2,91	7,60	72,3 lb
SVA 150	mm	90	572	483	594	505	91	370	315	74	219	60,0 kg
SVA (6)	in.	3,54	22,52	19,02	23,39	19,88	3,58	14,57	12,40	2,91	8,62	132,3 lb
SVA 200	mm	90	692	579	726	613	117	464	400	86	276	111,5 kg
SVA (8)	in.	3,54	27,24	22,80	28,58	24,13	4,61	18,27	15,75	3,39	10,87	245,8 lb

Los pesos especificados únicamente son valores aproximados.

Válvulas de cierre, SVA-S y SVA-L

Pedidos

Tamaños de conexión disponibles

SVA-S:

La **S** indica que se trata de una válvula con casquillo estándar (por el término inglés "Standard"); los tamaños DN 50-200 resultan aptos para su uso en sistemas aislados.

SVA-L:

La **L** indica que se trata de una válvula con casquillo Largo (apta para su uso en sistemas aislados).

Tamaño	SVA-S	SVA-L
6	x	
10	x	
15	x	x
20	x	x
25	x	x
32	x	x
40	x	x
50	x	
65	x	
80	x	
100	x	
125	x	
150	x	
200	x	

Tenga en cuenta que los códigos únicamente sirven para identificar las válvulas, algunas de las cuales no forman parte de la gama de productos estándar. Si desea obtener información complementaria, póngase en contacto con su distribuidor local de Danfoss.

Códigos

Tipo de válvula	SVA	Válvula de cierre																																																																																
Diámetro nominal en mm Nota: el tamaño de la válvula se mide tomando en consideración el diámetro de la conexión	6 10 15 20 25 32 40 50 65 80 100 125 150 200	<table border="1"> <thead> <tr> <th colspan="5">Conexiones disponibles</th> </tr> <tr> <th>A/D</th> <th>G</th> <th>SOC</th> <th>FPT</th> <th>T</th> </tr> </thead> <tbody> <tr><td>x</td><td></td><td></td><td></td><td>x</td></tr> <tr><td>x</td><td>x</td><td></td><td></td><td></td></tr> <tr><td>x</td><td>x</td><td>x</td><td>x</td><td></td></tr> <tr><td>x</td><td>x</td><td>x</td><td>x</td><td></td></tr> <tr><td>x</td><td>x</td><td>x</td><td>x</td><td></td></tr> <tr><td>x</td><td>x</td><td>x</td><td></td><td></td></tr> <tr><td>x</td><td>x</td><td></td><td></td><td></td></tr> <tr><td>x</td><td>x</td><td></td><td></td><td></td></tr> <tr><td>x</td><td>x</td><td></td><td></td><td></td></tr> <tr><td>x</td><td>x</td><td></td><td></td><td></td></tr> <tr><td>x</td><td>x</td><td></td><td></td><td></td></tr> <tr><td>x</td><td>x</td><td></td><td></td><td></td></tr> <tr><td>x</td><td></td><td></td><td></td><td></td></tr> <tr><td>x</td><td></td><td></td><td></td><td></td></tr> </tbody> </table>	Conexiones disponibles					A/D	G	SOC	FPT	T	x				x	x	x				x	x	x	x		x	x	x	x		x	x	x	x		x	x	x			x	x				x	x				x	x				x	x				x	x				x	x				x					x				
		Conexiones disponibles																																																																																
		A/D	G	SOC	FPT	T																																																																												
		x				x																																																																												
		x	x																																																																															
		x	x	x	x																																																																													
		x	x	x	x																																																																													
		x	x	x	x																																																																													
		x	x	x																																																																														
		x	x																																																																															
		x	x																																																																															
		x	x																																																																															
		x	x																																																																															
		x	x																																																																															
		x	x																																																																															
		x																																																																																
x																																																																																		
Conexiones	A Boquilla para soldar de acero ANSI B 36.10, calibre 80, DN 15-40 (½-1½ in) D Boquilla para soldar de acero ANSI B 36.10, calibre 40, DN 50-200 (2-8 in) G Boquilla para soldar de acero DIN EN 10220 SOC Boquilla para soldar de acero GOST (8734-75 + 8732-78) FPT Manguito para soldar de acero ANSI B 16.11 T Rosca hembra NPT ANSI/ASME B 1.20.1 Conexiones roscadas externas ISO 228/1																																																																																	
Carcasa de la válvula	ANG Paso en ángulo STR Paso recto																																																																																	
Otros accesorios	H-WHEEL Volante CAP Caperuza																																																																																	

Importante:

Si el producto debe estar homologado por algún organismo de homologación específico o necesita utilizar presiones superiores a las indicadas, incluya la información correspondiente en el momento de realizar el pedido.

Válvulas de cierre, SVA-S y SVA-L

Pedidos de válvulas SVA-S completas

Ejemplo:
Válvula SVA-S 20 DIN con paso en ángulo y volante = **148B5300**

Importante:

Si el producto debe estar homologado por algún organismo de homologación específico o necesita utilizar presiones superiores a las indicadas, incluya la información correspondiente en el momento de realizar el pedido.

SVA-S, paso en ángulo

Tamaño		Tipo	MWP		Referencia
mm	in.		bar	psi	

Boquilla para soldar de acero DIN (EN 10220)

6	¼	SVA-S 6 D ANG H-WHEEL	52	754	148B5000
6	¼	SVA-S 6 D ANG CAP	52	754	148B5001
10	¾	SVA-S 10 D ANG H-WHEEL	52	754	148B5100
10	¾	SVA-S 10 D ANG CAP	52	754	148B5101
15	½	SVA-S 15 D ANG H-WHEEL	52	754	148B5200
15	½	SVA-S 15 D ANG CAP	52	754	148B5201
20	¾	SVA-S 20 D ANG H-WHEEL	52	754	148B5300
20	¾	SVA-S 20 D ANG CAP	52	754	148B5301
25	1	SVA-S 25 D ANG H-WHEEL	52	754	148B5400
25	1	SVA-S 25 D ANG CAP	52	754	148B5401
32	1¼	SVA-S 32 D ANG H-WHEEL	52	754	148B5500
32	1¼	SVA-S 32 D ANG CAP	52	754	148B5501
40	1½	SVA-S 40 D ANG H-WHEEL	52	754	148B5600
40	1½	SVA-S 40 D ANG CAP	52	754	148B5601
50	2	SVA-S 50 D ANG H-WHEEL	52	754	148B5700
50	2	SVA-S 50 D ANG CAP	52	754	148B5701
65	2½	SVA-S 65 D ANG H-WHEEL	52	754	148B5800
65	2½	SVA-S 65 D ANG CAP	52	754	148B5801
80	3	SVA-S 80 D ANG H-WHEEL	52	754	148B5900
80	3	SVA-S 80 D ANG CAP	52	754	148B5901
100	4	SVA-S 100 D ANG H-WHEEL	52	754	148B6000
100	4	SVA-S 100 D ANG CAP	52	754	148B6001
125	5	SVA-S 125 D ANG H-WHEEL	52	754	148B6100
125	5	SVA-S 125 D ANG CAP	52	754	148B6101
150	6	SVA-S 150 D ANG H-WHEEL	52	754	148B6200
150	6	SVA-S 150 D ANG CAP	52	754	148B6201
200	8	SVA-S 200 D ANG H-WHEEL	52	754	148B6300
200	8	SVA-S 200 D ANG CAP	52	754	148B6301

Boquilla para soldar de acero ANSI (B 36.10, calibre 80)

6	¼	SVA-S 6 A ANG H-WHEEL	52	754	148B5020
6	¼	SVA-S 6 A ANG CAP	52	754	148B5021
10	¾	SVA-S 10 A ANG H-WHEEL	52	754	148B5120
10	¾	SVA-S 10 A ANG CAP	52	754	148B5121
15	½	SVA-S 15 A ANG H-WHEEL	52	754	148B5220
15	½	SVA-S 15 A ANG CAP	52	754	148B5221
20	¾	SVA-S 20 A ANG H-WHEEL	52	754	148B5320
20	¾	SVA-S 20 A ANG CAP	52	754	148B5321
25	1	SVA-S 25 A ANG H-WHEEL	52	754	148B5420
25	1	SVA-S 25 A ANG CAP	52	754	148B5421
32	1¼	SVA-S 32 A ANG H-WHEEL	52	754	148B5520
32	1¼	SVA-S 32 A ANG CAP	52	754	148B5521
40	1½	SVA-S 40 A ANG H-WHEEL	52	754	148B5620
40	1½	SVA-S 40 A ANG CAP	52	754	148B5621

Boquilla para soldar de acero ANSI (B 36.10, calibre 40)

50	2	SVA-S 50 A ANG H-WHEEL	52	754	148B5720
50	2	SVA-S 50 A ANG CAP	52	754	148B5721
65	2½	SVA-S 65 A ANG H-WHEEL	52	754	148B5820
65	2½	SVA-S 65 A ANG CAP	52	754	148B5821
80	3	SVA-S 80 A ANG H-WHEEL	52	754	148B5920
80	3	SVA-S 80 A ANG CAP	52	754	148B5921
100	4	SVA-S 100 A ANG H-WHEEL	52	754	148B6020
100	4	SVA-S 100 A ANG CAP	52	754	148B6021
125	5	SVA-S 125 A ANG H-WHEEL	52	754	148B6120
125	5	SVA-S 125 A ANG CAP	52	754	148B6121
150	6	SVA-S 150 A ANG H-WHEEL	52	754	148B6220
150	6	SVA-S 150 A ANG CAP	52	754	148B6221
200	8	SVA-S 200 A ANG H-WHEEL	52	754	148B6320
200	8	SVA-S 200 A ANG CAP	52	754	148B6321

Boquilla para soldar de acero, GOST

150	6	SVA-S 150 G ANG H-WHEEL	52	754	148B6240
150	6	SVA-S 150 G ANG CAP	52	754	148B6241

Manguito para soldar de acero ANSI (B 16.11)

15	½	SVA-S 15 SOC ANG H-WHEEL	52	754	148B5222
15	½	SVA-S 15 SOC ANG CAP	52	754	148B5223
20	¾	SVA-S 20 SOC ANG H-WHEEL	52	754	148B5322
20	¾	SVA-S 20 SOC ANG CAP	52	754	148B5323
25	1	SVA-S 25 SOC ANG H-WHEEL	52	754	148B5422
25	1	SVA-S 25 SOC ANG CAP	52	754	148B5423
32	1¼	SVA-S 32 SOC ANG H-WHEEL	52	754	148B5522
32	1¼	SVA-S 32 SOC ANG CAP	52	754	148B5523
40	1½	SVA-S 40 SOC ANG H-WHEEL	52	754	148B5622
40	1½	SVA-S 40 SOC ANG CAP	52	754	148B5623
50	2	SVA-S 50 SOC ANG H-WHEEL	52	754	148B5722
50	2	SVA-S 50 SOC ANG CAP	52	754	148B5723

Rosca interna hembra (FPT) NPT (ANSI/ASME B 1.20.1)

15	½	SVA-S 15 FPT ANG H-WHEEL	52	754	148B5224
15	½	SVA-S 15 FPT ANG CAP	52	754	148B5225
20	¾	SVA-S 20 FPT ANG H-WHEEL	52	754	148B5324
20	¾	SVA-S 20 FPT ANG CAP	52	754	148B5325
25	1	SVA-S 25 FPT ANG H-WHEEL	52	754	148B5424
25	1	SVA-S 25 FPT ANG CAP	52	754	148B5425
32	1¼	SVA-S 32 FPT ANG H-WHEEL	52	754	148B5524
32	1¼	SVA-S 32 FPT ANG CAP	52	754	148B5525

Rosca externa T (ISO 228/1)

6	¼	SVA-S 6 T ANG CAP	52	754	148B5032
---	---	-------------------	----	-----	----------

SVA-S, paso recto

Tamaño		Tipo	MWP		Referencia
mm	in.		bar	psi	

Boquilla para soldar de acero DIN (EN 10220)

6	¼	SVA-S 6 D STR H-WHEEL	52	754	148B5010
6	¼	SVA-S 6 D STR CAP	52	754	148B5011
10	¾	SVA-S 10 D STR H-WHEEL	52	754	148B5110
10	¾	SVA-S 10 D STR CAP	52	754	148B5111
15	½	SVA-S 15 D STR H-WHEEL	52	754	148B5210
15	½	SVA-S 15 D STR CAP	52	754	148B5211
20	¾	SVA-S 20 D STR H-WHEEL	52	754	148B5310
20	¾	SVA-S 20 D STR CAP	52	754	148B5311
25	1	SVA-S 25 D STR H-WHEEL	52	754	148B5410
25	1	SVA-S 25 D STR CAP	52	754	148B5411
32	1¼	SVA-S 32 D STR H-WHEEL	52	754	148B5510
32	1¼	SVA-S 32 D STR CAP	52	754	148B5511
40	1½	SVA-S 40 D STR H-WHEEL	52	754	148B5610
40	1½	SVA-S 40 D STR CAP	52	754	148B5611
50	2	SVA-S 50 D STR H-WHEEL	52	754	148B5710
50	2	SVA-S 50 D STR CAP	52	754	148B5711
65	2½	SVA-S 65 D STR H-WHEEL	52	754	148B5810
65	2½	SVA-S 65 D STR CAP	52	754	148B5811
80	3	SVA-S 80 D STR H-WHEEL	52	754	148B5910
80	3	SVA-S 80 D STR CAP	52	754	148B5911
100	4	SVA-S 100 D STR H-WHEEL	52	754	148B6010
100	4	SVA-S 100 D STR CAP	52	754	148B6011
125	5	SVA-S 125 D STR H-WHEEL	52	754	148B6110
125	5	SVA-S 125 D STR CAP	52	754	148B6111
150	6	SVA-S 150 D STR H-WHEEL	52	754	148B6210
150	6	SVA-S 150 D STR CAP	52	754	148B6211
200	8	SVA-S 200 D STR H-WHEEL	52	754	148B6310
200	8	SVA-S 200 D STR CAP	52	754	148B6311

Boquilla para soldar de acero ANSI (B 36.10, calibre 80)

6	¼	SVA-S 6 A STR H-WHEEL	52	754	148B5030
6	¼	SVA-S 6 A STR CAP	52	754	148B5031
10	¾	SVA-S 10 A STR H-WHEEL	52	754	148B5130
10	¾	SVA-S 10 A STR CAP	52	754	148B5131
15	½	SVA-S 15 A STR H-WHEEL	52	754	148B5230
15	½	SVA-S 15 A STR CAP	52	754	148B5231
20	¾	SVA-S 20 A STR H-WHEEL	52	754	148B5330
20	¾	SVA-S 20 A STR CAP	52	754	148B5331
25	1	SVA-S 25 A STR H-WHEEL	52	754	148B5430
25	1	SVA-S 25 A STR CAP	52	754	148B5431
32	1¼	SVA-S 32 A STR H-WHEEL	52	754	148B5530
32	1¼	SVA-S 32 A STR CAP	52	754	148B5531
40	1½	SVA-S 40 A STR H-WHEEL	52	754	148B5630
40	1½	SVA-S 40 A STR CAP	52	754	148B5631

Boquilla para soldar de acero ANSI (B 36.10, calibre 40)

50	2	SVA-S 50 A STR H-WHEEL	52	754	148B5730
50	2	SVA-S 50 A STR CAP	52	754	148B5731
65	2½	SVA-S 65 A STR H-WHEEL	52	754	148B5830
65	2½	SVA-S 65 A STR CAP	52	754	148B5831
80	3	SVA-S 80 A STR H-WHEEL	52	754	148B5930
80	3	SVA-S 80 A STR CAP	52	754	148B5931
100	4	SVA-S 100 A STR H-WHEEL	52	754	148B6030
100	4	SVA-S 100 A STR CAP	52	754	148B6031
125	5	SVA-S 125 A STR H-WHEEL	52	754	148B6130
125	5	SVA-S 125 A STR CAP	52	754	148B6131
150	6	SVA-S 150 A STR H-WHEEL	52	754	148B6230
150	6	SVA-S 150 A STR CAP	52	754	148B6231
200	8	SVA-S 200 A STR H-WHEEL	52	754	148B6330
200	8	SVA-S 200 A STR CAP	52	754	148B6331

Boquilla para soldar de acero, GOST

150	6	SVA-S 150 G STR H-WHEEL	52	754	148B6250
150	6	SVA-S 150 G STR CAP	52	754	148B6251

Manguito para soldar de acero ANSI (B 16.11)

15	½	SVA-S 15 SOC STR H-WHEEL	52	754	148B5232
15	½	SVA-S 15 SOC STR CAP	52	754	148B5233
20	¾	SVA-S 20 SOC STR H-WHEEL	52	754	148B5332
20	¾	SVA-S 20 SOC STR CAP	52	754	148B5333
25	1	SVA-S 25 SOC STR H-WHEEL	52	754	148B5432
25	1	SVA-S 25 SOC STR CAP	52	754	148B5433
32	1¼	SVA-S 32 SOC STR H-WHEEL	52	754	148B5532
32	1¼	SVA-S 32 SOC STR CAP	52	754	148B5533
40	1½	SVA-S 40 SOC STR H-WHEEL	52	754	148B5632
40	1½	SVA-S 40 SOC STR CAP	52	754	148B5633
50	2	SVA-S 50 SOC STR H-WHEEL	52	754	148B5732
50	2	SVA-S 50 SOC STR CAP	52	754	148B5733

Rosca interna hembra (FPT) NPT (ANSI/ASME B 1.20.1)

15	½	SVA-S 15 FPT STR H-WHEEL	52	754	148B5234
15	½	SVA-S 15 FPT STR CAP	52	754	148B5235
20	¾	SVA-S 20 FPT STR H-WHEEL	52	754	148B5334
20	¾	SVA-S 20 FPT STR CAP	52	754	148B5335
25	1	SVA-S 25 FPT STR H-WHEEL	52	754	148B5434
25	1	SVA-S 25 FPT STR CAP	52	754	148B5435
32	1¼	SVA-S 32 FPT STR H-WHEEL	52	754	148B5534
32	1¼	SVA-S 32 FPT STR CAP	52	754	148B5535

ANG = Paso en ángulo
STR = Paso recto

CAP = Caperuza
H-WHEEL = Volante

Válvulas de cierre, SVA-S y SVA-L

Pedidos de válvulas SVA-L completas

Ejemplo:
Válvula SVA-L 20 DIN con paso en ángulo y volante = **148B5340**

Importante:

Si el producto debe estar homologado por algún organismo de homologación específico o necesita utilizar presiones superiores a las indicadas, incluya la información correspondiente en el momento de realizar el pedido.

SVA-L, paso en ángulo

Tamaño		Tipo	MWP		Referencia
mm	in.		bar	psi	

Boquilla para soldar de acero DIN (EN 10220)

15	½	SVA-L 15 D ANG H-WHEEL	52	754	148B5240
15	½	SVA-L 15 D ANG CAP	52	754	148B5241
20	¾	SVA-L 20 D ANG H-WHEEL	52	754	148B5340
20	¾	SVA-L 20 D ANG CAP	52	754	148B5341
25	1	SVA-L 25 D ANG H-WHEEL	52	754	148B5440
25	1	SVA-L 25 D ANG CAP	52	754	148B5441
32	1¼	SVA-L 32 D ANG H-WHEEL	52	754	148B5540
32	1¼	SVA-L 32 D ANG CAP	52	754	148B5541
40	1½	SVA-L 40 D ANG H-WHEEL	52	754	148B5640
40	1½	SVA-L 40 D ANG CAP	52	754	148B5641

Boquilla para soldar de acero ANSI (B 36.10, calibre 80)

15	½	SVA-L 15 A ANG H-WHEEL	52	754	148B5260
15	½	SVA-L 15 A ANG CAP	52	754	148B5261
20	¾	SVA-L 20 A ANG H-WHEEL	52	754	148B5360
20	¾	SVA-L 20 A ANG CAP	52	754	148B5361
25	1	SVA-L 25 A ANG H-WHEEL	52	754	148B5460
25	1	SVA-L 25 A ANG CAP	52	754	148B5461
32	1¼	SVA-L 32 A ANG H-WHEEL	52	754	148B5560
32	1¼	SVA-L 32 A ANG CAP	52	754	148B5561
40	1½	SVA-L 40 A ANG H-WHEEL	52	754	148B5660
40	1½	SVA-L 40 A ANG CAP	52	754	148B5661

Manguito para soldar de acero ANSI (B 16.11)

15	½	SVA-L 15 SOC ANG H-WHEEL	52	754	148B5262
15	½	SVA-L 15 SOC ANG CAP	52	754	148B5263
20	¾	SVA-L 20 SOC ANG H-WHEEL	52	754	148B5362
20	¾	SVA-L 20 SOC ANG CAP	52	754	148B5363
25	1	SVA-L 25 SOC ANG H-WHEEL	52	754	148B5462
25	1	SVA-L 25 SOC ANG CAP	52	754	148B5463
32	1¼	SVA-L 32 SOC ANG H-WHEEL	52	754	148B5562
32	1¼	SVA-L 32 SOC ANG CAP	52	754	148B5563
40	1½	SVA-L 40 SOC ANG H-WHEEL	52	754	148B5662
40	1½	SVA-L 40 SOC ANG CAP	52	754	148B5663

Rosca interna hembra (FPT) NPT (ANSI/ASME B 1.20.1)

15	½	SVA-L 15 FPT ANG H-WHEEL	52	754	148B5264
15	½	SVA-L 15 FPT ANG CAP	52	754	148B5265
20	¾	SVA-L 20 FPT ANG H-WHEEL	52	754	148B5364
20	¾	SVA-L 20 FPT ANG CAP	52	754	148B5365
25	1	SVA-L 25 FPT ANG H-WHEEL	52	754	148B5464
25	1	SVA-L 25 FPT ANG CAP	52	754	148B5465
32	1¼	SVA-L 32 FPT ANG H-WHEEL	52	754	148B5564
32	1¼	SVA-L 32 FPT ANG CAP	52	754	148B5565

SVA-L, paso recto

Tamaño		Tipo	MWP		Referencia
mm	in.		bar	psi	

Boquilla para soldar de acero DIN (EN 10220)

15	½	SVA-L 15 D STR H-WHEEL	52	754	148B5250
15	½	SVA-L 15 D STR CAP	52	754	148B5251
20	¾	SVA-L 20 D STR H-WHEEL	52	754	148B5350
20	¾	SVA-L 20 D STR CAP	52	754	148B5351
25	1	SVA-L 25 D STR H-WHEEL	52	754	148B5450
25	1	SVA-L 25 D STR CAP	52	754	148B5451
32	1¼	SVA-L 32 D STR H-WHEEL	52	754	148B5550
32	1¼	SVA-L 32 D STR CAP	52	754	148B5551
40	1½	SVA-L 40 D STR H-WHEEL	52	754	148B5650
40	1½	SVA-L 40 D STR CAP	52	754	148B5651

Boquilla para soldar de acero ANSI (B 36.10, calibre 80)

15	½	SVA-L 15 A STR H-WHEEL	52	754	148B5270
15	½	SVA-L 15 A STR CAP	52	754	148B5271
20	¾	SVA-L 20 A STR H-WHEEL	52	754	148B5370
20	¾	SVA-L 20 A STR CAP	52	754	148B5371
25	1	SVA-L 25 A STR H-WHEEL	52	754	148B5470
25	1	SVA-L 25 A STR CAP	52	754	148B5471
32	1¼	SVA-L 32 A STR H-WHEEL	52	754	148B5570
32	1¼	SVA-L 32 A STR CAP	52	754	148B5571
40	1½	SVA-L 40 A STR H-WHEEL	52	754	148B5670
40	1½	SVA-L 40 A STR CAP	52	754	148B5671

Manguito para soldar de acero ANSI (B 16.11)

15	½	SVA-L 15 SOC STR H-WHEEL	52	754	148B5272
15	½	SVA-L 15 SOC STR CAP	52	754	148B5273
20	¾	SVA-L 20 SOC STR H-WHEEL	52	754	148B5372
20	¾	SVA-L 20 SOC STR CAP	52	754	148B5373
25	1	SVA-L 25 SOC STR H-WHEEL	52	754	148B5472
25	1	SVA-L 25 SOC STR CAP	52	754	148B5473
32	1¼	SVA-L 32 SOC STR H-WHEEL	52	754	148B5572
32	1¼	SVA-L 32 SOC STR CAP	52	754	148B5573
40	1½	SVA-L 40 SOC STR H-WHEEL	52	754	148B5672
40	1½	SVA-L 40 SOC STR CAP	52	754	148B5673

Rosca interna hembra (FPT) NPT (ANSI/ASME B 1.20.1)

15	½	SVA-L 15 FPT STR H-WHEEL	52	754	148B5274
15	½	SVA-L 15 FPT STR CAP	52	754	148B5275
20	¾	SVA-L 20 FPT STR H-WHEEL	52	754	148B5374
20	¾	SVA-L 20 FPT STR CAP	52	754	148B5375
25	1	SVA-L 25 FPT STR H-WHEEL	52	754	148B5474
25	1	SVA-L 25 FPT STR CAP	52	754	148B5475
32	1¼	SVA-L 32 FPT STR H-WHEEL	52	754	148B5574
32	1¼	SVA-L 32 FPT STR CAP	52	754	148B5575

ANG = Paso en ángulo

STR = Paso recto

CAP = Caperuza

H-WHEEL = Volante

Accesorios

Kits de manguitos 6T

Referencia	
148B4245	ACCESSORY WELD.NIPPLE DN6 A + UNION NUT
148B4184	ACCESSORY WELD.NIPPLE DN6 D + UNION NUT

Válvulas de cierre, SVA-S y SVA-L

Pedidos de válvulas SVA-S empleando el catálogo de piezas

Ejemplo

(selección a partir de las tablas 1 y 2)



Tabla 1

Carcasas de válvula SVL c/diferentes conexiones

Nota:

No todos los tamaños están disponibles para válvulas SVA-L; consulte la tabla 2.

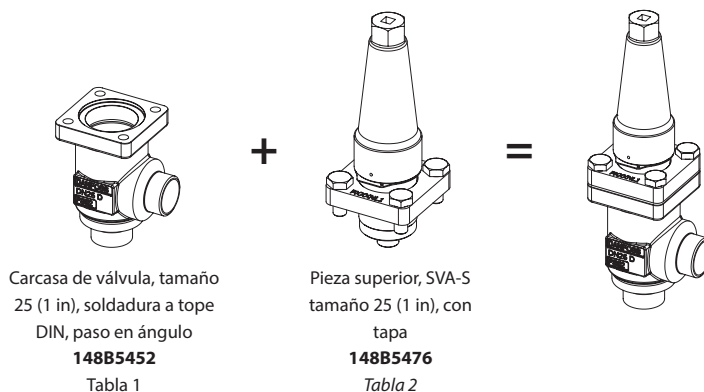

		DN 6-10 mm (¼ - ¾ in.)				DN 15-65 mm (½ - 2½ in.)				DN 80-125 mm (3 - 5 in.)			
													
Tamaños [DN]		Carcasa de válvula SVL											
		Soldadura a tope DIN		Soldadura a tope ANSI		Soldadura a tope GOST		SOC		FPT		T	
mm	in.	ANG	STR	ANG	STR	ANG	STR	ANG	STR	ANG	STR	ANG	
6	¼	148B5002	148B5003	148B5004	148B5005								148B5012
10	¾	148B5122	148B5123	148B5124	148B5125	148B5134	148B5135						
15	½	148B5252	148B5253	148B5254	148B5255	148B5391	148B5392	148B5256	148B5257	148B5258	148B5259		
20	¾	148B5352	148B5353	148B5354	148B5355	148B5393	148B5394	148B5356	148B5357	148B5358	148B5359		
25	1	148B5452	148B5453	148B5454	148B5455	148B5498	148B5499	148B5456	148B5457	148B5458	148B5459		
32	1¼	148B5576	148B5577	148B5578	148B5579	148B5593	148B5594	148B5580	148B5581	148B5582	148B5583		
40	1½	148B5652	148B5653	148B5654	148B5655	148B5681	148B5682	148B5656	148B5657				
50	2	148B5741	148B5742	148B5743	148B5744	148B5759	148B5760	148B5745	148B5746				
65	2½	148B5816	148B5817	148B5818	148B5819	148B5819	148B5816						
80	3	148B5912	148B5913	148B5914	148B5915	148B5915	148B5912						
100	4	148B6014	148B6015	148B6016	148B6017	148B6033	148B6034						
125	5	148B6112	148B6113	148B6114	148B6115	148B6133	148B6134						

Tabla 2

Pieza superior completa para SVA, incluye juntas y pernos

		SVA-S 6-10 con tapa	SVA-S 6-10 con volante	SVA-S 15-65 con tapa	SVA-S 15-65 con volante	SVA-S 80-125 con tapa	SVA-S 80-125 con volante	SVA-L 15-40 con tapa	SVA-L 15-40 con volante
									
Tamaños [DN]		Pieza superior completa							
mm	in.	SVA-S con tapa		SVA-S con volante		SVA-L con tapa		SVA-L con volante	
6	¼	148B5013		148B5014					
10	¾	148B5276		148B5277		148B5278		148B5279	
15	½	148B5476		148B5477		148B5478		148B5479	
20	¾								
25	1								
32	1¼								
40	1½								
50	2	148B5728		148B5729					
65	2½	148B5822		148B5823					
80	3	148B5916		148B5917					
100	4	148B6012		148B6018					
125	5	148B6116		148B6117					

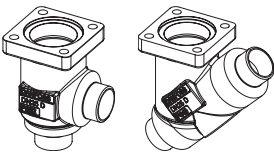
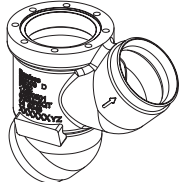
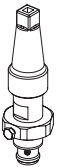
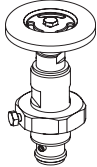
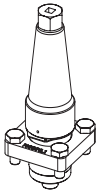
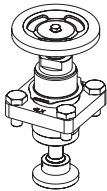
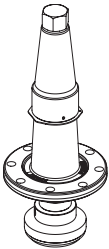
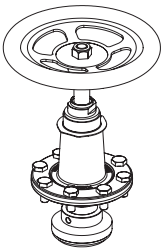
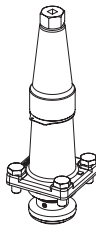
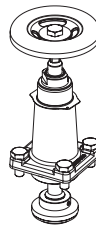